

SUPER CHALLENGER MOTOR AS-SERIES

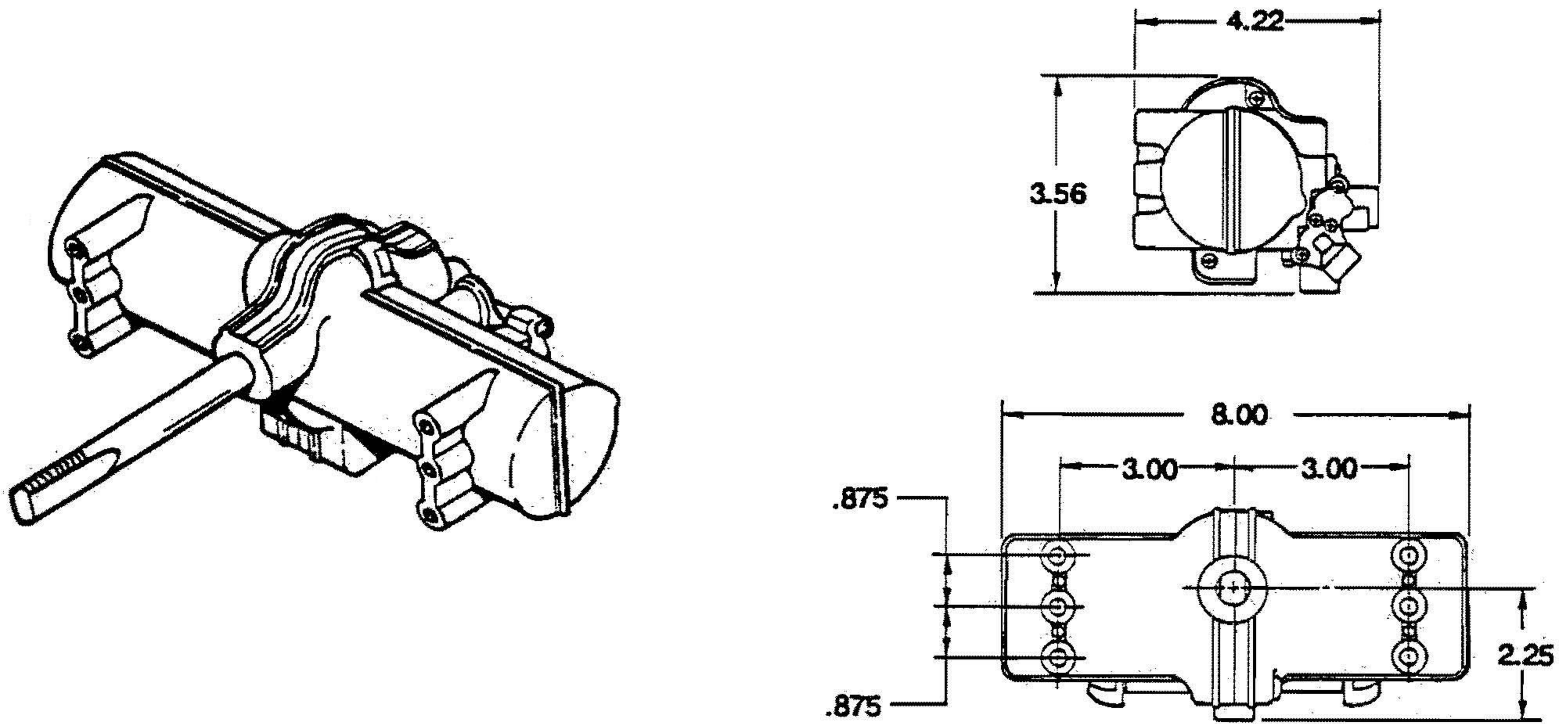

EXAMPLE - AS1/075003/302

SERIES NUMBER	OLD MOTOR NUMBER
AS-1	M-550-DEG
AS-2	M-550-1-DEG
AS-3	M-551-DEG
AS-4	M-554-DEG
AS-5	M-557-DEG
AS-6	M-556-DEG

AIR CONSUMPTION - 1.8 C.F.M. AT 100 P.S.I.

TORQUE - 20 FT. LBS. AT 100 P.S.I.

WEIGHT - 3.0 LBS. (APPROX.)

OPERATING PRESSURE - 30 TO 100 P.S.I.

SWEEP RANGE - 30 DEG. TO 140 DEG.